

PHYZ SPRINGBOARD: UNDERSTANDING RAINBOWS



Understanding a rainbow requires a synthesis of physics and geometry. The physics is simple and the geometry is simple. But the synthesis is complex. So hang on and play along; it **will** come together.

1. Geometry Review: π in the Sky

Suppose a laser beam were shining down toward you from some altitude as shown to the right. Suppose also that you held a tube in front of one eye and your other eye were closed.

a. Under what conditions could you see light directly from the laser?

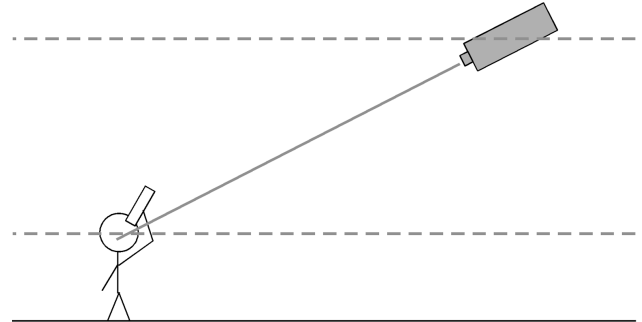

b. If the beam were angled 60° below the horizontal, how high above the horizon would you have to look to see the beam? What principle of geometry supports your conclusion?

2. The Rainbow in Two Dimensions

Imagine you are looking at the full splendor of a rainbow. Now imagine that you close one eye and look at the rainbow through a vertical slit (such as if your hands were held in front of your face so as to completely block your view and then separated by about one centimeter to form a gap through which you can look).

a. In your rainbow slice, what is the order of colors from top to bottom?

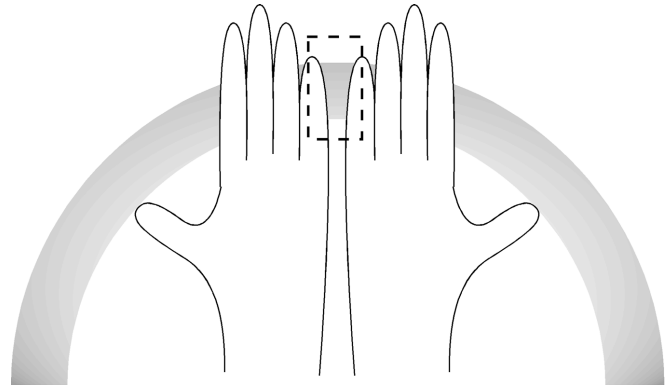

The elements required to form a typical rainbow are sunlight and rain. The geometry is shown to the right. Colored light comes from the raindrops after they refract and reflect the sunlight.

b. In your thin slit view of the rainbow, which color comes from which raindrop? Label the raindrops on the diagram to the right.

c. But wait. In a few moments drop 1 will fall to the position of drop 5. In your view of the rainbow, which color will come from it then?

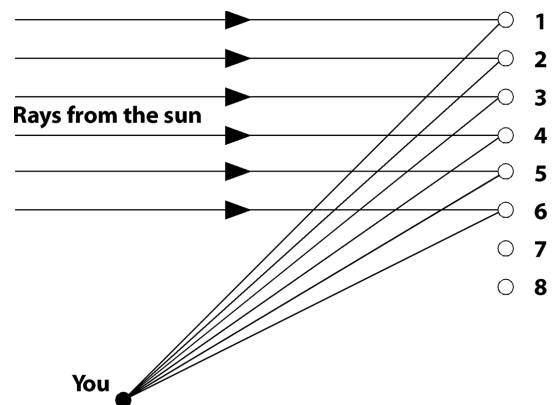

The composition and geometry of the raindrop does something to the sunlight. Consider a single spherical raindrop, drawn as a circle to the right. Sunlight comes in from the left and a spectrum comes out at about 40° - 42° below the normal, directed back to the left. Red light comes out at the greatest angle (42°), violet comes out at a smaller angle (40°).



d. Draw and label the beams on the diagram to the right.

e. How high in the sky (angle above the horizon) will violet light appear in the sky?

f. How high in the sky (angle above the horizon) will red light appear in the sky?

✓. Is this consistent with the color order you mentioned in part b.?

3. Sweep It Out

Instead of just appearing 40° - 42° above the horizon, the colored light comes to you at 40° - 42° away from the direction straight ahead of you. That's how the full rainbow appears before you.

a. In the diagram to the right, where is the sun and where is the rain?

b. What angle is the direction opposite of 0° ?

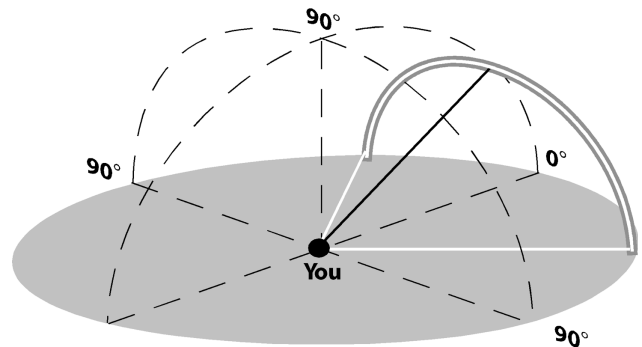

4. What's Going On? (Draw as you go)

a. White light incident on the raindrop reflects and refracts into a raindrop. When it does so, some of the sunlight's intensity is lost by reflection and the refracted light is dispersed.

b. Some of the red light reflects from the back surface of the drop. Some of the violet light is reflected, too, but at a slightly different angle due to the curved nature of the surface.

✓. Does the color pattern match the one shown in the diagram you drew in 2.d. above?

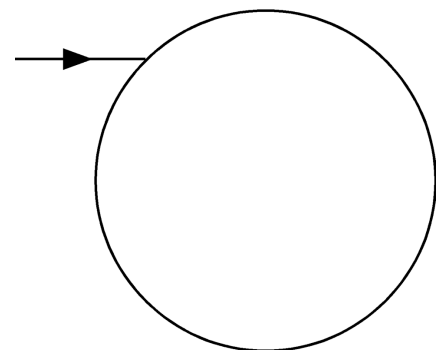

c. Some of the light exits along the bottom of the drop. The additional refraction causes further dispersion. Red light comes out at the greatest angle (42°), violet comes out at a smaller angle (40°).

d. But wait. The beams also come out at 40° - 42° **above** the normal. Label the color of the rays coming out of the raindrop to the right.

e. The raindrop is spherical, not circular. (What's the difference?) So the colored light emerges at 40° - 42° in all other directions away from the normal. Sketch the resulting _____ of red light and violet light emerging from the single spherical raindrop. It is this

_____ that by geometry and the presence of a wide field of raindrops allows us to see a circular rainbow.

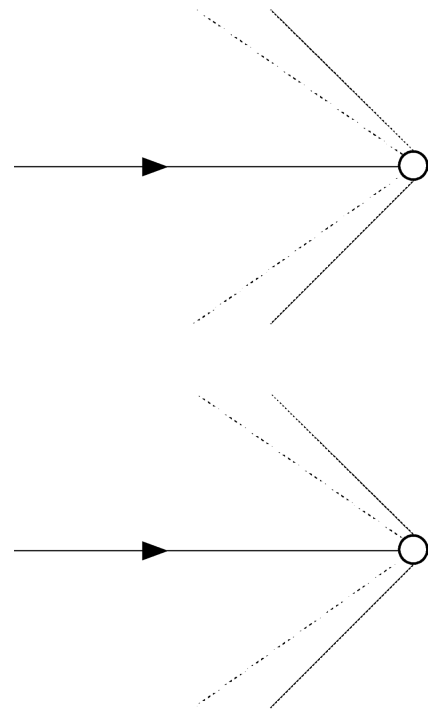

5. Rainbows Have Depth

For the sake of the following exercise, we will assume a wider dispersion of colors. Suppose that red light emerges at 60° from the normal and violet light emerges at 30° .

a. Draw a line from your position (little dude) through the drops in the raindrop field at 30° above the horizon. Each drop intersected by your line shines at you with violet light.

b. Repeat with a line at 60° to locate red-shining raindrops.

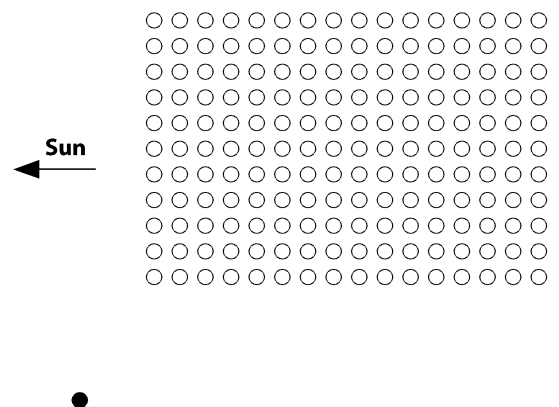

6. Chasing A Rainbow

To person A, the gray raindrop shown appears to be reflecting violet light.

a. How do you suppose that drop appears to person B?

b. Darken **one column** of drops that are part of A's rainbow and repeat for person B's rainbow. Start with the bottom (violet) drop and work straight up. Label the rainbows A and B.

c. Suppose person A chases the rainbow to position B. Will she get closer to the rainbow?

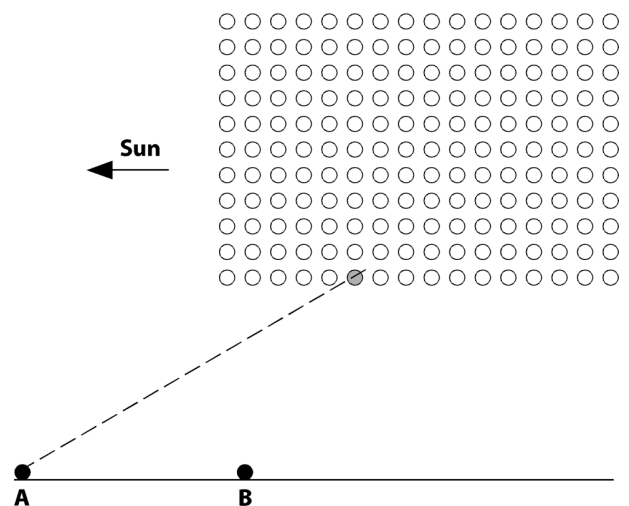

7. The Full Rainbow

Remember that each drop sends out cones of colored light: as much light at 41° above the normal as 41° below the normal. Consider a little dudette in a helicopter. The sun is behind her and there is a field of raindrops in front of her.

a. Will she see reflected/dispersed light coming toward her from 41° above her?

b. Will she see reflected/dispersed light coming toward her from 41° **below** her?

c. Will she see reflected/dispersed light coming toward her from 41° to her left, right, and all around her?

d. Taken as a whole, what will she see?

e. Why don't land-bound people enjoy the same spectacle?

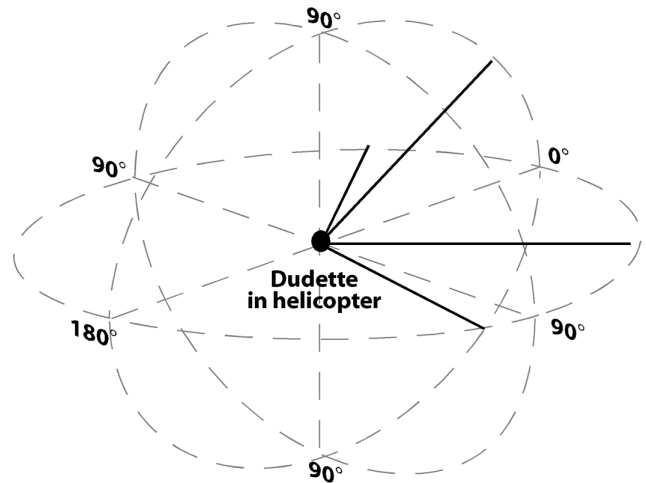

8. An Item of Secondary Importance

Another set of reflections and refractions occurs within each raindrop as shown to the right.

a. What optical phenomenon results from this?

b. Discuss the order of the colors of this phenomenon.

c. The light that emerges comes out at about 53° from the incident ray. Will this phenomenon appear higher or lower in the sky than the rainbow discussed earlier?

d. Why is this phenomenon relatively dim?

